

CONSEW

014

OPERATING INSTRUCTION

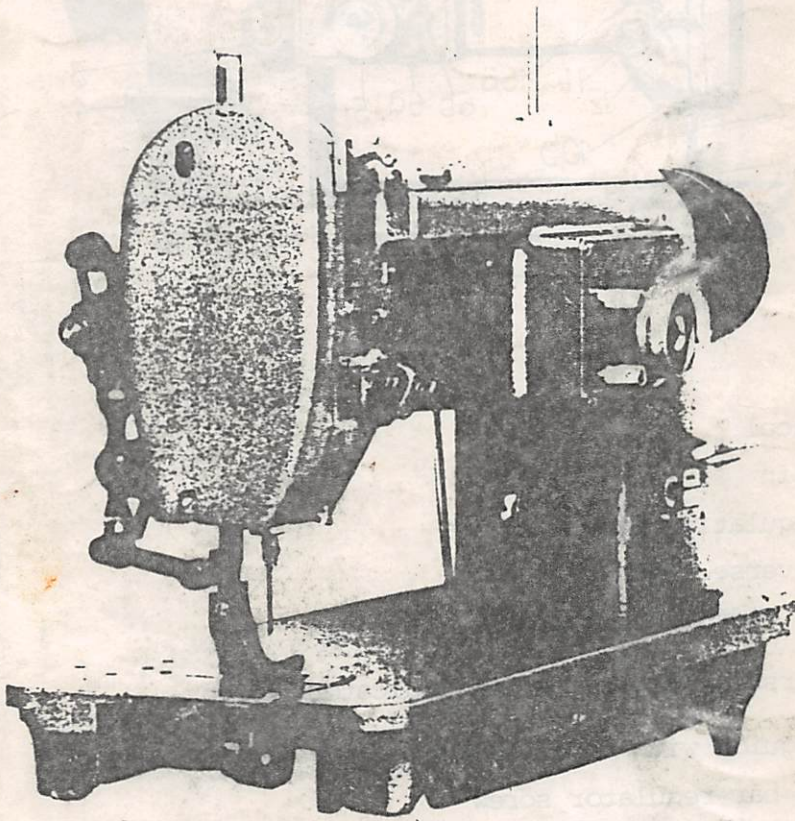

MODEL 146RBL-1A
146RB-1A

CONSEW INTERNATIONAL LTD.



Yamajin Bldg., 18, 1-chome, Hon-machi, Higashi-ku, Osaka, 541 Japan.
P. O. Box: Osaka Higashi No. 509
Telephones: Osaka (06) 261-3291 ~ 3297
Cable Address: "CONSEWMACH" Osaka
Telex: J64459 CONSEW Fax: (06) 261-3298

I. HOW TO USE MACHINE

=====

1. NAMES OF MAIN PARTS

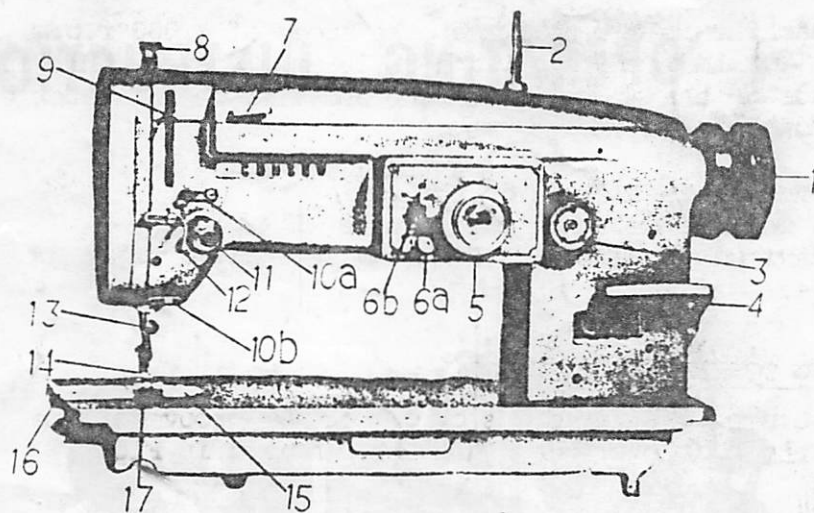

(Fig. 1)

1. Hand Wheel
2. Spool pin
3. Feed Regulating dial
4. Feed reverse lever
5. Zig-zag width indicator
- 6a. Stoppers for zig-zag width indicator
- 6b. Stoppers for zig-zag width indicator
7. Thread guide with three holes
8. Presser bar regulator screw
9. Thread take-up lever
- 10a. Upper Arm Thread guide
- 10b. Lower Arm Thread guide
11. Upper thread tension regulator
12. Tension post thread guide
13. Needle bar and needle bar thread guide
14. Presser foot
15. Throat plate
16. Slide plate
17. Feed dog

2. SPOOL PIN

For the convenient sake of packing, the spool pin is removed from the machine and packed separate in the accessory box. Put the pin as shown in Fig. 1 - #2.

3. SPEED

The machine is set to run at the speed of 3,000 r.p.m. at the maximum zig-zag width of 10 mm. However, this speed depends on the electric current and also the diameter of the motor pulley being used.

In order to assure the durability of the machine, it is recommended that the machine will be used at the maximum speed of 2,500 r.p.m. at the beginning of use.

4. OILING TO THE ROTATING HOOK

Please supply a few drops of oil to the groove of the rotating hook every day. (As arrow-marked in Fig. 2)



(Fig. 2)

5. NEEDLE AND THREAD

The size of the needle to be used should be determined by the size of the thread as well as the materials to be sewn. The needle should be set with its groove facing toward you, as shown in the Fig. 3.

<u>Needle and Thread Chart</u>	
<u>Thread size</u>	<u>Needle Size</u>
#120 - #100	# 9
100 - 80	11
80 - 60	14
60 - 40	16
40 - 20	19
20 - 16	21

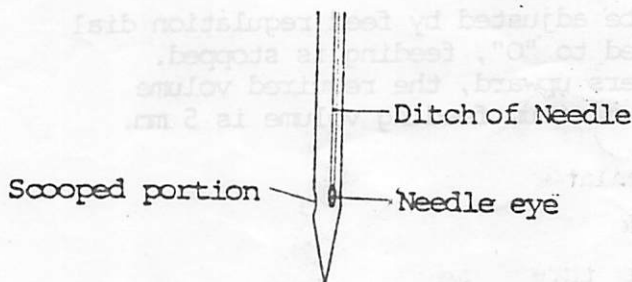

6. OILING

It is most important that the machine is properly oiled every day.

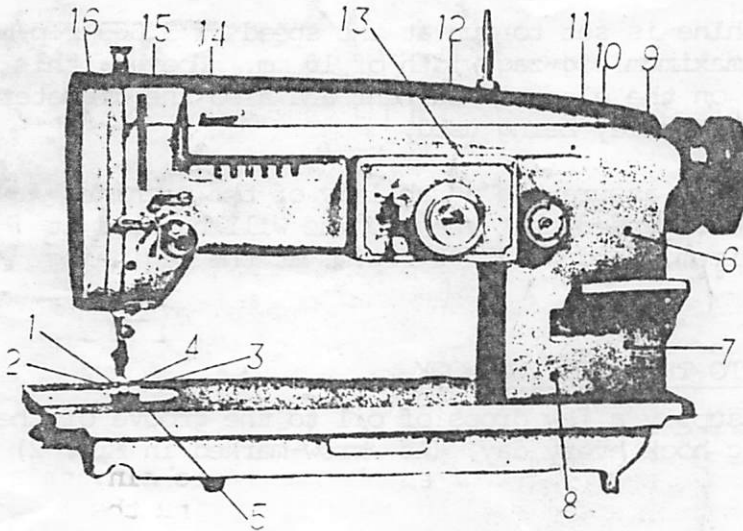

(Fig. 4)

One or two drops of oil would be supplied to all the spots indicated in the Fig. 4.

7. ADJUSTMENT OF ZIGZAG WIDTH AND FEEDING VOLUME

- 1) Adjustment of Zigzag width can be made by Zigzag regulator dial. When straight sewing is required, please place the dial to "0" and gradually raising numbers, zigzag width will be widened up to the maximum width of 10 mm.
2. Feeding volume can be adjusted by feed regulation dial and when it is placed to "0", feeding is stopped. By raising the numbers upward, the required volume is obtained and the maximum feeding volume is 5 mm.

HOW TO THREAD THE MACHINE

Starting from the spool pin (1), please lead the thread as per the following manner.

- (2) Three hole thread eyelet-
- (3) Tension disc.
- (4) Tension spring
- (5) Tension post thread guide
- (6) Upper arm thread guide
- (7) Take up lever
- (8) Tension post thread guide
- (9) Lower arm thread guide
- (10) Needle bar thread guide
- (11) Needle

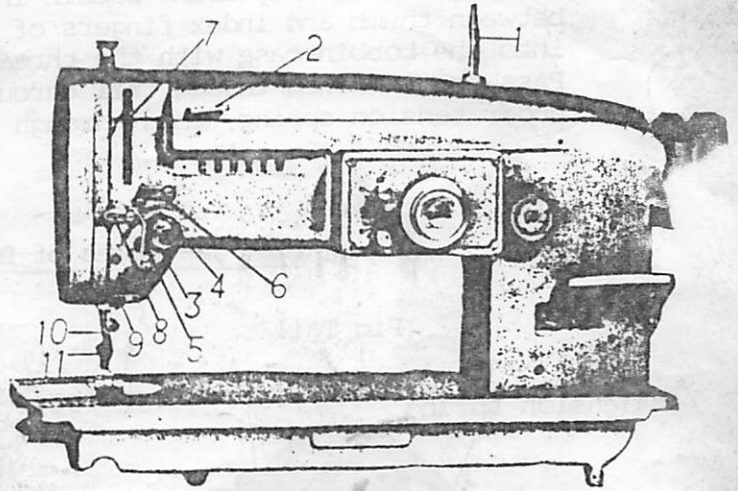
HOW TO WIND BOBBIN

(Fig. 5)

If the bobbin thread does not wind evenly on the bobbin, this will affect the stitch and please be careful to wind the thread to bobbin as per the following.

1. Push the bobbin on the bobbin winder spindle as far as it will go.
2. Bring the thread forward toward the bobbin and wind from below in clockwise direction several times around the bobbin.
3. Push the bobbin winder lever downward until the wheel contacts the drive belt, and then start the machine.
4. Adjustment screw (4) can be turned in or out to increase or decrease the amount of thread to be wound on the bobbin.

If the thread does not wind evenly on the bobbin, adjust the tension thread guard by moving to right or left as may be required.

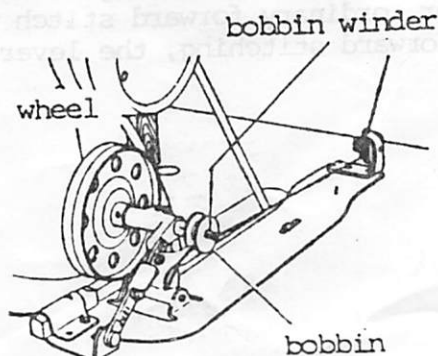

(Fig. 6)

10. INSERTING THE BOBBIN IN THE BOBBIN CASE

To insert the fully wound bobbin in the bobbin case, hold it between thumb and index fingers of your left hand and place into the bobbin case with the thread tail remained outside. Pass the remained thread tail through the slot of bobbin case, under tension spring, then through the pig tail thread guide.

Fig. 7 - Names of Bobbin Case

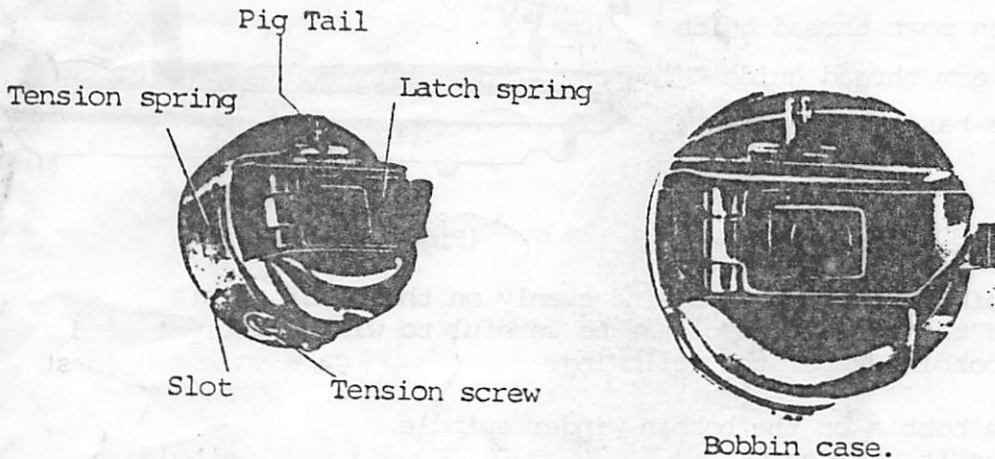

11. REGULATING THE THREAD TENSION

For ordinary stitching, the tension of the upper and lower thread should be equal so as to lock both threads in the center of the fabric.

The tension of the bobbin thread is regulated by means of the tension screw, but it is preferable to keep it rather weak. Once it is regulated, the perfect stitch can be obtained by adjusting the tension of upper thread by increasing or decreasing the tension.

12. REVERSE STITCH

For reversing the feed of the machine, keep the feed reverse lever #4 (In Fig. 1) depressed as long as required and if release the lever, ordinary forward stitch will be done. (For all other forward stitching, the lever remains in up position).

13. REGULATING PRESSURE ON MATERIAL.

Always use the lightest pressure possible to allow the smooth feed of material. It can be adjusted by turning the regulating screw. To increase the pressure, turn the screw to the right and to decrease it to the left.

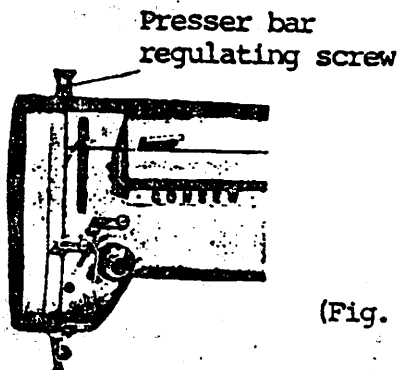

(Fig. 8)

14. PREPARATION FOR SEWING

1. Turn the balance wheel toward you with the right hand until the needle moves down and up again to its highest point, thus catching the lower (bobbin) thread.
2. Now pull the end of the upper thread you are holding and the bobbin thread will be brought up with it through the needle hole in the throat plate and place both ends of the thread back under the presser foot.
3. Place the fabric to be sewn beneath the presser foot, lower the foot upon it and then start sewing the machine.

TO REMOVE FABRIC AFTER SEWING

Raise the needle bar to its highest point, lift the presser foot and draw the fabric back and to the left. Cut the ends of the thread a few inches long from the needle.

II ADJUSTMENT

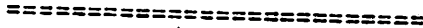

1. ADJUSTMENT FOR STRAIGHT SEWING (Ref. Fig. 9)

At the time of despatch from the factory, the machine is so adjusted that the zig-zag regulator is fixed at "0".

If not, please reset the indicator dial at "0" and run machine to assure that accurate straight stitches be obtained. Should you fail to obtain accurate straight stitches by the above, please loosen regulator screw (A), then adjust zig-zag width regulator (B) by moving it sideways, until you obtain accurate straight stitches. After adjustment is made correctly, set the screws (A) and (B) tight with indicator points "0".

2. ADJUSTMENT FOR CENTERING THE NEEDLE (Ref. Fig. 10)

Set the zig-zag regulating dial for straight stitch sewing and turn hand wheel towards you until the needle reaches its lowest point of its downward stroke. See that the needle enters the needle slot in the throat (needle) plate at the very center. And also see that the hook point meets the vertical center of needle, at this position. If it does not, adjust the needle bar frame pitman eccentric stud "D" (Fig. 11) by loosening the set screw "C".

3. ADJUSTMENT OF ZIGZAG MOVEMENT (Ref. Fig. 11)

In case the zig zag drive cam is found wrongly situated, make the needle to reach its lowest point and tighten the set screw "E" of the cam to come to the top, as shown in the Fig. 11.

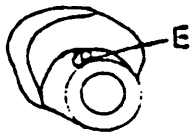

Zigzag drive cam.
(Fig. 11)

Zigzag Regulator
B

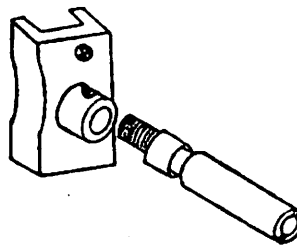

(Fig. 9)

Adjusting Screw A

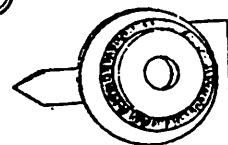

Zigzag regulati

Knob
(DIAL)

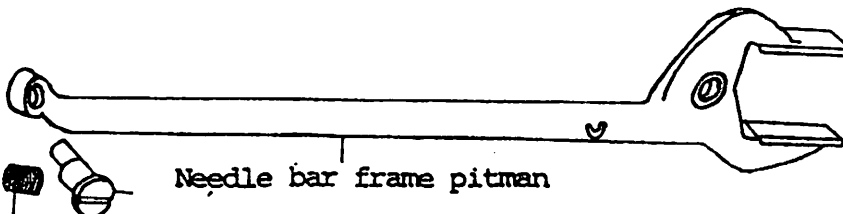

Needle bar frame pitman

(Fig. 10)

Set screw Eccentric Stud Pin

4. ADJUSTMENT OF UPPER FEED MECHANISM. (Ref. Fig. 12)

(For the type with upper feed mechanism,
146RB-1A and 146RBL-1A)

- A. To increase the lifting volume of outer foot.
 - 1. Loosen the adjusting belt A (#752).
 - 2. Raise the position of Rock Shaft Crank (#751) as you desire.
 - 3. Set the bolt tightly, after adjustment.
- B. To obtain more lifting volume of outer foot.
 - 1. Loosen the adjusting bolt B (#752).
 - 2. Raise the position of lifting crank connecting line #748) as you desire.
 - 3. Reset the bolt tightly, after adjustment.
- C. To increase the feeding volume of order foot.
 - 1. Loosen the adjusting bolt C. (#733).
 - 2. Raise the position of feed correcting link (#732) as you desire.
 - 3. Reset the bolt, after adjustment.

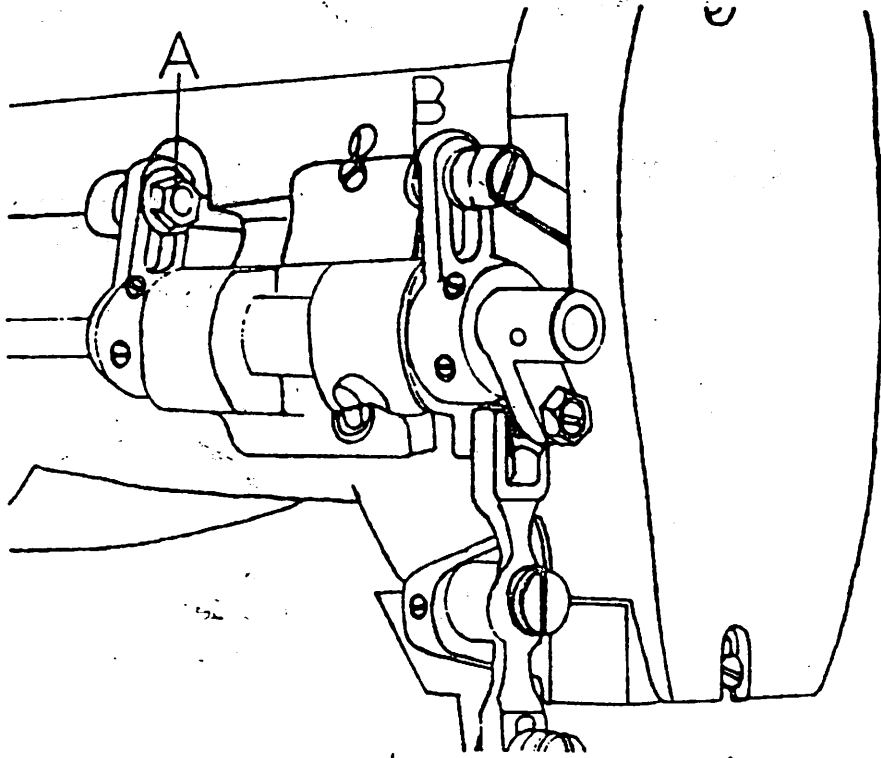

(Fig. 12)

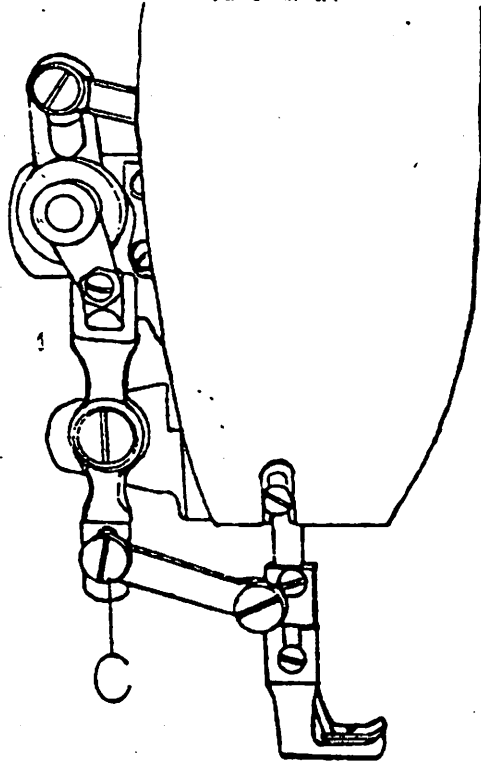

5. ADJUSTMENT OF NEEDLE TIMING AT ITS LOWEST POSITION (Ref. Fig. 13)

Remove face plate and loosen the screw (#209) of needle bar bracket (#206). Turn the hand wheel (#240) slowly towards you until the needle bar F (#707) is aligned with the screw (#211) of needle bar crank rod (#210). This is considered the lowest position of needle.

6. ADJUSTMENT OF TIMING BETWEEN NEEDLE AND HOOK (Needle being used is type DP x 17)

1. Turn the zig-zag dial right to the largest width of 10 mm and have the needle reach at its rightest and lowest point.
2. Then set the hook so that the end of hook gib comes 0.5 mm right of needle "L". (Ref. Fig. 14)
3. Turn the hand wheel to the leftest and lowest position. See that the hook point travels 1 mm above the thread hole of the needle. (Ref. Fig. 15)
4. When sewing the different materials, it is recommended that the timing explained above is a little delayed.

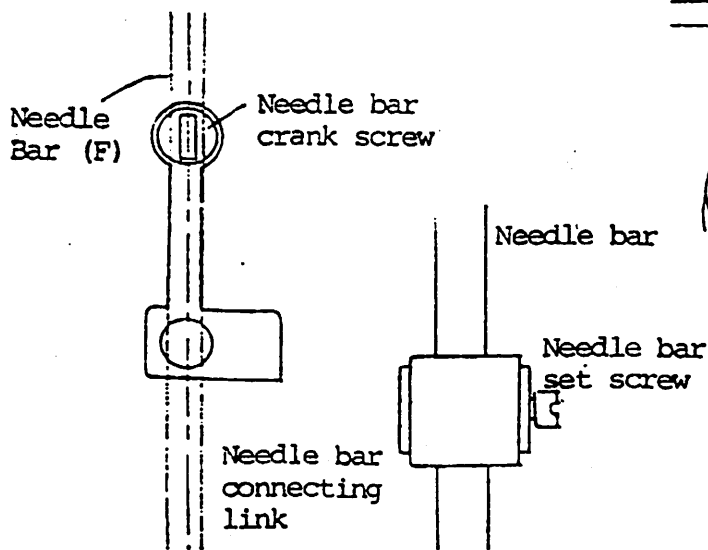

(Fig. 13)

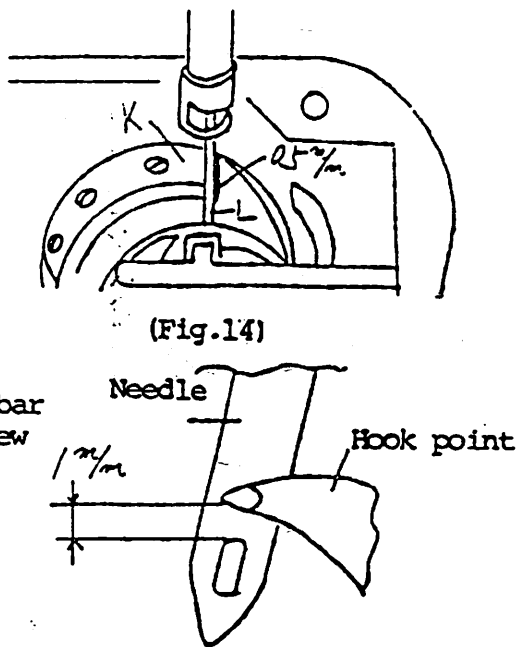

(Fig. 14)

(Fig. 15)

TROUBLE SHOOT

=====

If following problems be occurred, please check the points as suggested below.

* - marked be checked carefully.

** - marked be most carefully checked.

Thread breakage

- ** - Any damage on the hook? (Please carefully check on the hook point).
- Is timing between needle and hook correct?
- * - Isn't hook point worn out?
- * - Is quality of thread good?
- Any scratch on thread guides?
- ** - Any damage or scratch on hook retainer?
- Is needle all right?
- * - Any damage on needle plate, particularly around needle hole?
- * - Is check spring correct, not too hard?
- No lints in bobbin case?

Cloth breakage

- * - Isn't the machine too old to cause excessive play on all moving parts?
- * - Does needle penetrate center of needle hole on needle plate?
- * - No bent needle used?
- * - No too much play on zig zag drive fork?
- Is thread tension correct?

Skipping of stitch

- * - Is the timing of needle to hook correct? Not too early, not too late?
- No bent needle used?
- No worn out on hook point?
- * - No excessive play on needle bar?
- * - No excessive clearance between needle and hook point?
- * - Isn't needle hole of needle plate too large to the size of needle used?

Thread Breakage (On straight sewing).

- * - No excessive clearance between needle and hook point?
- * - Is hook timing correct? Not too early?
- * - Isn't check spring too hard?
- * - Does check spring moves freely?

Needle Breakage

- * - Doesn't needle hit needle plate?
- * - Is the clearance between needle and hook point correct?
- ** - No excessive play on needle bar frame?
- ** - No excessive play on hook shaft thrust collar?